

- e) Characterization of NERAUS Motor
- i. Low noise;
 - ii. Low currency consumption which enable the batter to worker longer after one charge;
 - iii. Battery capacity saving system: when you are trolling with low speed, the currency would be lower, that means the battery can work longer when the trolling motor working with low speed;
 - iv. Strong: we use Strong composite fibre glass shaft, which can endure very strong hit and weight;
 - v. Long-time continuous working: it can continuous working over 500 hours in test;
 - vi. Can be use in salt water: the coating can endure acid, therefore the salt water will not rust the motor. But to use in salt water, the end-user must make speical maintaining after using.
 - vii. NRS-T series trolling motor control box can be turned when user operate and it has three retainer at aclinic position and $\pm 30^\circ$ position,also it has limit position at $\pm 35^\circ$.
 - viii. All trolling motor equipped with a 10 LED Lights Battery Indicator which can let you know the level of the power left. It not only can tell you whenever the power is low but also protect your battery from damage
 - ix. User can easily operate the trolling motor with a wide range of functions, 5 forward speeds, 3 reverse speeds and 6'' telescopic handle. The design of switch and handles are made up of the highest quality function of al trolling motor. Also this trolling motor comes with battery connection clip which make the connection fast and convenient

II.

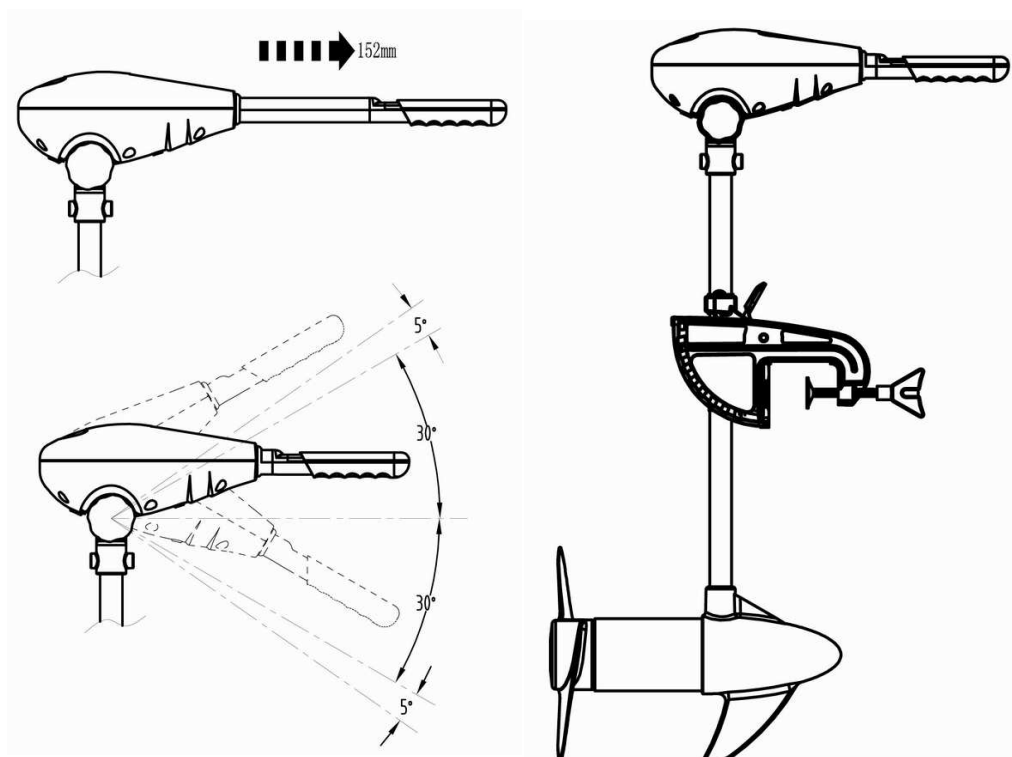

Functions

a) Input Power and thrust

Power is not the most important case for trolling, what really counts is how big is the thrust made by the motor. Therefore, most trolling motor only offer the value of thrust.

Item No.	Thrust in LBS	Thrust in KG	Input	Input Power
NRS-32T	32LBS	14.5kg	12V, 26A	312W
NRS-36T	36LBS	16.3kg	12V, 29A	348W
NRS-40T	40LBS	18.1kg	12V, 34A	408W
NRS-46T	46LBS	20.9kg	12V, 40A	480W
NRS-50T	50LBS	22.7kg	12V, 46A	552W
NRS-55T	55LBS	25.0kg	12V, 52A	624W
NRS-86T	86LBS	37.2kg	24V, 48A	1152W

b) Power of different stages

F: forward R: reverse

Item No.	R3	R2	R1	F1	F2	F3	F4	F5
NRS-32T	312W	95W	57W	57W	75w	95w	124W	312W
NRS-36T	348W	106W	64W	64W	84w	106w	138W	348W
NRS-40T	408W	124W	75W	75W	99w	124w	162W	408W
NRS-46T	480W	146W	88W	88W	116w	146w	190W	480W
NRS-50T	552W	168W	101W	101W	133w	168w	218W	552W
NRS-55T	624W	190W	114W	114W	150w	190w	246W	624W
NRS-86T	1152W	420W	228W	228W	290w	420w	523W	1152W

c) Maximum Speed

Since the speed depends on many factors, such as loading, water speed, wind etc., it would be difficult to describe the speed, we give the speed for reference as following:

Boat Size: 2.6m

Loading: 90kg

Water: Quiet water

Item No.	Speed (approximately)
NRS-32T	5km/h
NRS-36T	6.5km/h
NRS-40T	7.8km/h
NRS-46T	9.5km/h
NRS-50T	12km/h
NRS-55T	14.5km/h
NRS-86T	22km/h

d) Boat size and loaded capacity

Item No.	Max Boat Size	
NRS-32T	12'~14',	3.65m~4.26m
NRS-36T	12'~14',	3.65m~4.26m
NRS-40T	16'~17',	4.86m~5.17m
NRS-46T	16'~17',	4.86m~5.17m
NRS-50T	18'~20',	5.48m~6.08m
NRS-55T	18'~20',	5.48m~6.08m
NRS-86T	22'~24',	6.69m~7.30m

Voltage Meter



There are 10 LED on the meter, 7 upper LEDs are green and 3 lower LEDs are red, when all the green LEDs are turned off, that means the input voltage is lower than 10.25V, you must turn off the motor and disconnect the motor from the battery, otherwise it may cause forever damage to the battery.

e) Maintaining

- If you want to use this motor in Salt water, please use daub Antirust oil on the metal parts that are exposed to the salt water.
- After used in salt water, please use fresh water to clean it and then dry it.
- Keep the products clean and dry after use.
- Save the products in the original package.
- The control box can only be opened by professional engineer.
- Do not use in water area with many water plants or other sundries in water.
- Never connect the wire with wrong electrode. Must disconnect with battery during maintenance.
- Never leave the motor in environment over 60°C.
- Never stop the propeller with strong objects while the motor is running.
- Get rid of any water grass or other dirt attached to the motor after use, this cleaning work must be carried after the motor were used for 20 hours.
- To prevent accidental damage during trailering or storage, disconnect the battery whenever the motor is off of the water. For prolonged storage, lightly coat all metal parts with silicone spray.
- If this edge of propeller is rough or nicked, restore to smooth by sanding with fine sandpaper

f) Warning

- This is not a life saving device.
- Do not leave children unattended while device is in use.
- The user must be dressed with life saving coat.
- Please read the user's manual carefully.
- Never put the control box in water, if it fell into water completely, you must send it to professional people to clean it before use.
- Never unfix any part of this motor.
- Only use this products between -20°C to $+45^{\circ}\text{C}$ (-4°F to 113°F).
- Never replace any parts with the parts from other supplier.
- Ensure sufficient battery charge remaining, when there is only 3 lights is bright on the voltage meter, the motor must be unconnected with the batteries immediately.
- Never stick body parts, clothing or other objects in the vicinity of the propeller. Do not wear loose or flowing clothing or equipment that could be drawn into the propeller.
- Particular care should be exercised when using this item near anybody with long hair. Users with long hair should tie it up or wear swimming caps when using the boat.
- Always inspect the swimming area to ensure it is free of hazards or danger such as boats and swimmers before using the boat.
- Always wear a coast guard approved personal flotation device when using the boat with this motor.
- A child under 16 years old or end-user cannot swim should NEVER operate the boat independently. A child under 14 years old should never operate this product.
- Never use when the wave is over 1m high.
- Never unfix the product in water or when it is wet.
- Never put the upper part with handle in water, if it got wet, the user must disconnect the battery and try to clean and dry it.
- Never put the control box in water deeper than 5 meters.
- Keep lead wire connection tight and solid to battery terminals.
- Use 6-gauge wire to extend power lead.
- Locate battery in a ventilated compartment.

III. Key Points for Quality

- Motor Rotor: we are offer very high quality Rotor which can endure over loading for over 150 seconds;
- Plug: We are using Nex plug, which is the best plug. If the plug is with poor quality, since the currency for trolling motor is very high, it is very easily cause damage to the plug and finally make quality problem;
- Cable: We are using AWM cable, this cable can up to all U.S.A standard and European standard, even the currency is very big, it will not become hot and soft;
- Switch: Our switch can endure over 12,000 times switch.